

NOTE:
AAR APPROVAL # E-182113.

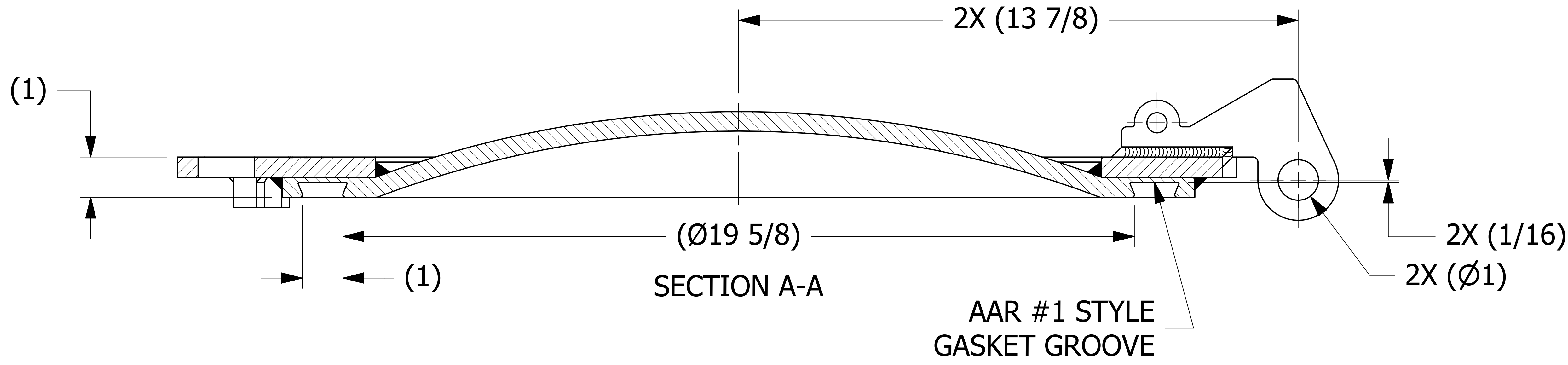

H	WEB	5-20-19	REMOVED QAP4A-1 NOTE; Q-2.15.7 WAS QAP4C-1; UPDATED WELD NOTE TO D-008; ADDED D-005 NOTE; AAR # WAS E-089004
G	RJP	11-16-17	HINGE WELD WAS 3/8"; 4.00 +.00/-.06 WAS 4.00; ADDED NOTE 6; ADDED "SALCO" TO ENGRAVING
F	JG	1-27-17	TMCDR20411 WAS TMCR204S601 & TMCDSS6MF; UPDATED NOTES, VIEWS; REMOVED VIEW D-D
E	WEB	11-24-15	REPLACED TMCHS4A WITH 2X C42806
D	CHL	3-14-13	ADDED NOTE #5 & HEAT/LOT NOTE
C	GDS	10-20-11	ADDED VIEW D-D
B	CHL	10-29-10	UPDATED NOTES, REPLACED A14392 W/A29293, UPDATED WELD SYMBOL, ADDED PART NUMBER TO RING SURFACE
A	CHL	7-20-10	NEW PART ADDED TO SYSTEM
REV	BY	DATE	DESCRIPTION

<small>UNLESS OTHERWISE SPECIFIED DIMENSIONAL TOLERANCES FRACTIONAL: ±1/16 X.XX: ±.03 X.XXX: ±.015 ANGULAR: ±1° DEBURR ALL SHARP EDGES. ALL MACHINED SURFACES TO HAVE A 125 RMS FINISH UNLESS NOTED OTHERWISE. THIRD ANGLE PROJECTION</small>	DRAWN BY:	CHL
	CHECKED BY:	VD
	PROTOTYPE BY:	CHL
	PROTOTYPE DATE:	5/28/2010
	APPROVED FOR PRODUCTION BY:	VD
	PRODUCTION DATE:	7/20/2010

SALCO PRODUCTS, INC.			
PART NAME: MANWAY COVER 20" 8-BOLT			
MATERIAL: 316L SS			
PROJECT #:	WAG0834	SHEET #:	1 OF 1
DRAWING #:		SCALE: 2:3	
E28860		TMC2041101	